

CAD FILE:

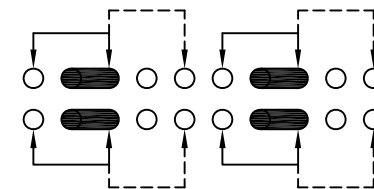

SCHEMATIC (NON-SHORTING)

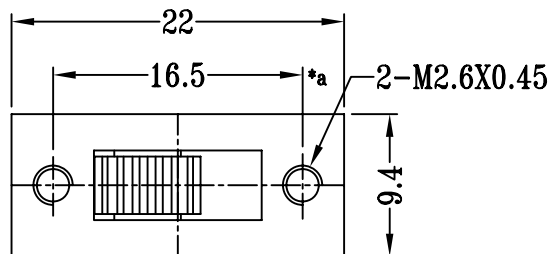
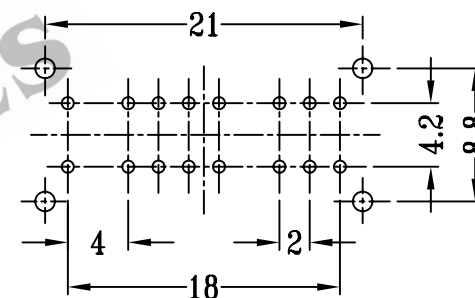
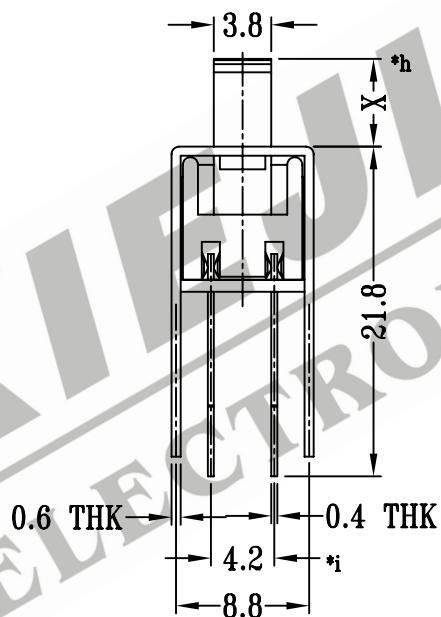
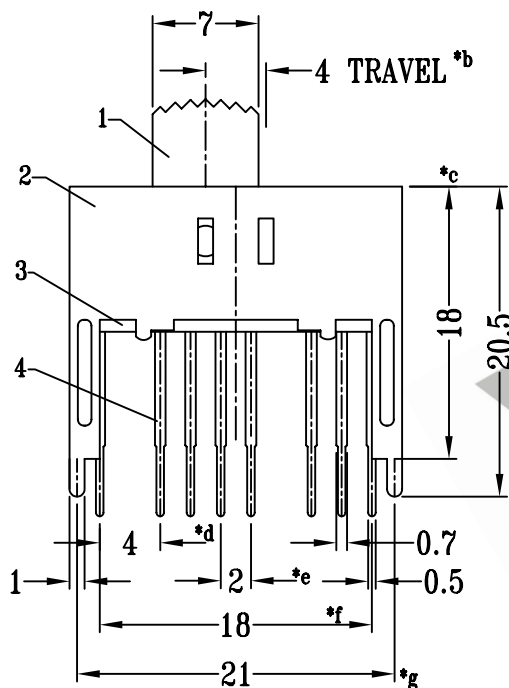

P.C.B LAYOUT

注:带"\*"表示关键尺寸(9个)

8					TOLERANCE UNLESS SPECIFIED	SHENZHEN XIEJIA ELECTRONICS CO.,LTD.				
7	STEEL BALL	STEEL	2	NATURAL	WITHIN: 1.5±0.1mm	ISSUE	DATE	DESCRIPTIONS		APPD.
6	SPRING	STEEL WIRE	1	TEMPER	OVER : 1.5±0.2mm					
5	CONTACT CLIP	PBS STRIP	4	Ag PLATED	TITLE : VERTICAL SLIDE SWITCH		UNIT : MM	DRWG NO.: XJ-DR-SS42H10-00		
4	TERMINAL	BRASS STRIP	16	Ag PLATED OVER Ni PLATED	MODEL: SS-42H10		SCALE: 2:1	DWN.	ZHOUYU	2005-3-19
3	BASE	PHENOLIC RESIN	1	NATURAL	ALL MATERIALS MUST BE COMPLIANT TO ROHS			CHK'D	FANGYING	2005-3-19
2	FRAME	STEEL STRIP	1	Ni PLATED				APPD.	KANGXINAN	2005-3-19
1	KNOB	POM	1	BLACK						
NO.	PART NAME	MATERIAL	Q'TY	FINISHING						